



U.S. Department
of Transportation

**Federal Highway
Administration**

400 Seventh St., S.W.
Washington, D.C. 20590

May 7, 1998

Refer to: HNG-14

J. M. Essex, P.E.
Senior Vice President, Sales
Energy Absorption Systems, Inc.
One East Wacker Drive
Chicago, Illinois 60601

Dear Mr. Essex:

In your April 1 letter to Mr. Henry Rentz, you requested acceptance of a modified Triton Barrier as a National Cooperative Highway Research Program (NCHRP) Report 350 test level 3 (TL-3) temporary barrier. Your letter also requested Federal Highway Administration's (FHWA) acceptance of a further-modified Triton configuration to function as a TL-3 terminal for the barrier. This second request will be addressed in a separate letter.

To support your request for acceptance of the Triton Barrier at TL-3, you also sent copies of your December 19, 1997, report entitled "TRITON BARRIER TL-3: Qualification to NCHRP Report 350 TL-3 - Engineering Summary," which included the full report prepared by E-TECH Testing Services, Inc., entitled "NCHRP Report 350 Crash Test Results for the TRITON BARRIER TL-3," dated December 1997, and a video tape showing the full scale tests that you conducted on the modified Triton Barrier. We noted that the Triton Barrier TL-3 modules have the same exterior dimensions as those tested earlier to obtain TL-2 acceptance but that the interior U-bolts at the ends of each module are double-nutted to the interior steel framework in the TL-3 units. Each module is set on two 178-mm high plastic pedestals to raise its center of gravity in order to meet TL-3 evaluation criteria. These pedestals are strapped to each individual unit and are also tethered together (in groups of ten) with a braided polyester cord to reduce debris scatter following an impact. We understand that all new modules will be made with the two-nut connection noted above and that all pedestals shipped to the field separately for use with earlier-manufactured modules will include extra nuts and instructions to modify any existing segments that have only a single nut connection. Enclosure 1 shows the details of the TL-3 design.

The NCHRP Report 350 recommends two tests for longitudinal barriers: tests 3-10 and 3-11, the first being an 820-kg car impacting at 100 km/h and at a 20-degree angle and the second being a 2000-kg pickup truck impacting at 100 km/h and at a 25-degree angle. You ran test 3-11 twice to determine the number of modules needed in advance of the barrier length of need to ensure vehicle containment. In the first test, the vehicle impacted near the center of a 30-module array. In the second, the impact point was between modules ten and eleven. You then concluded that at least ten water-filled modules are needed in advance of the barrier length of need.

Although both strength tests met NCHRP Report 350 evaluation criteria, barrier deflection was reported as 5.8 and 6.9 meters, respectively. You then ran a non-standard test to determine the outcome of a more typical hit. When impacted with a 2000-kg pickup truck at 100 km/h and 7 degrees, the truck was contained and redirected parallel to the barrier, which deflected only 1.4 meters. User agencies should be informed of the range of deflections to be expected and advised to ensure that these distances are available in any given work zone or that the likelihood of high angle (or heavy vehicle) impacts is low enough to result in an acceptable risk when lesser clearances are available. The results of each of the four tests you reported are shown in Enclosure 2.

Based on our review of the information you provided, we concur that the Triton Barrier, as modified and tested, meets the acceptance criteria for an NCHRP Report 350 TL-3 crash cushion. Because it is a proprietary device, its use on Federal-aid projects, except exempt, non-National Highway System projects, remains subject to the conditions listed in Title 23, Code of Federal Regulations, Section 635.411 when such use is specified by the contracting authority.

Sincerely yours,



Dwight A. Horne
Chief, Federal-Aid and Design Division

2 Enclosures

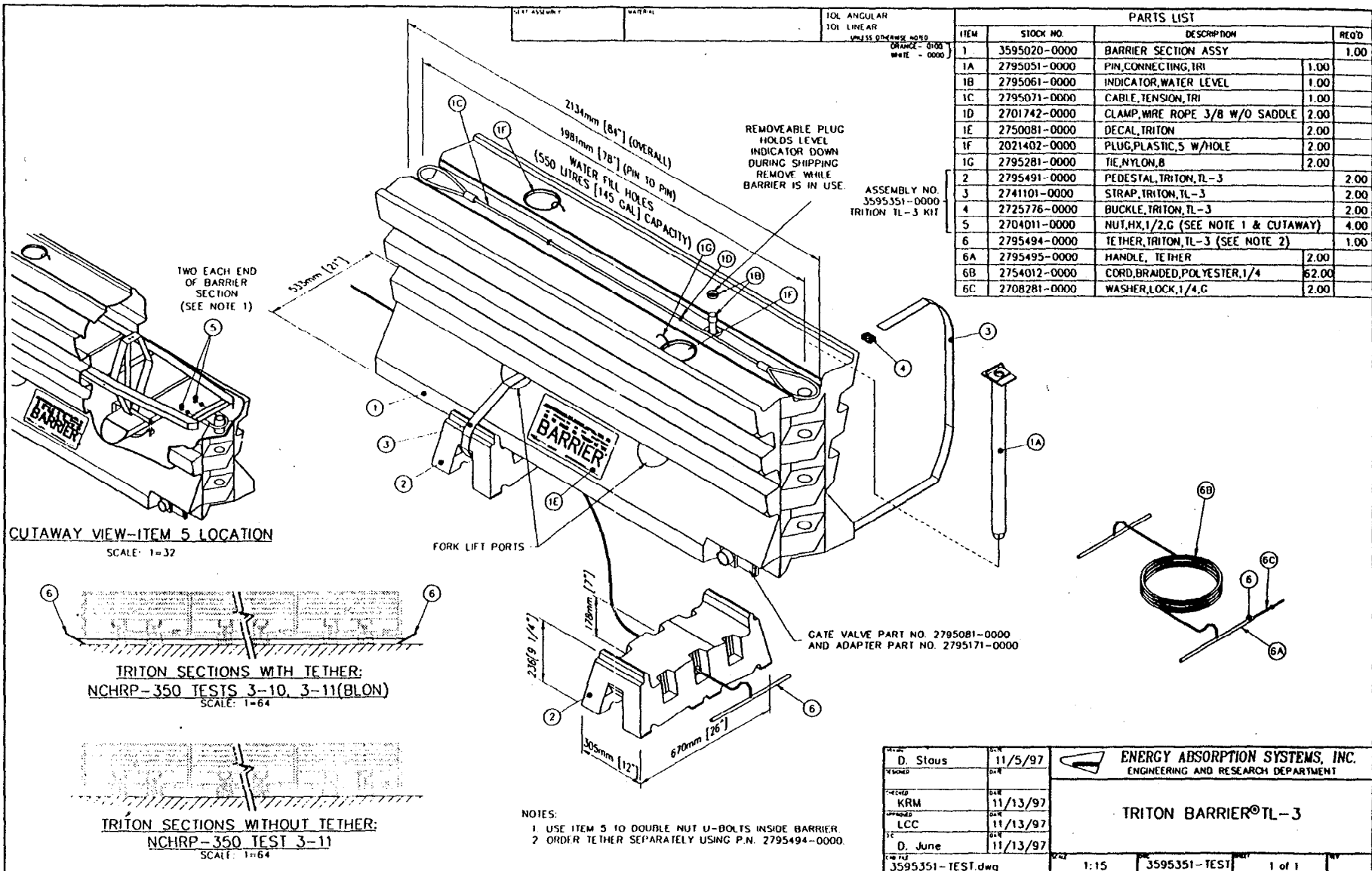

PARTS LIST			
ITEM	STOCK NO.	DESCRIPTION	REQD
1	3595020-0000	BARRIER SECTION ASSY	1.00
1A	2795051-0000	PIN,CONNECTING,TRI	1.00
1B	2795061-0000	INDICATOR,WATER LEVEL	1.00
1C	2795071-0000	CABLE,TENSION,TRI	1.00
1D	2701742-0000	CLAMP,WIRE ROPE 3/8 W/O SADDLE	2.00
1E	2750081-0000	DECAL,TRITON	2.00
1F	2021402-0000	PLUG,PLASTIC,5 W/HOLE	2.00
1G	2795281-0000	TIE,NYLON,8	2.00
2	2795491-0000	PEDESTAL,TRITON,TL-3	2.00
3	2741101-0000	STRAP,TRITON,TL-3	2.00
4	2725776-0000	BUCKLE,TRITON,TL-3	2.00
5	2704011-0000	NUT,HX,1/2,G (SEE NOTE 1 & CUTAWAY)	4.00
6	2795494-0000	TETHER,TRITON,TL-3 (SEE NOTE 2)	1.00
6A	2795495-0000	HANDLE, TETHER	2.00
6B	2754012-0000	CORD,BRAIDED,POLYESTER,1/4	62.00
6C	2708281-0000	WASHER,LOCK,1/4,G	2.00

CUTAWAY VIEW-ITEM 5 LOCATION
SCALE: 1=32

TRITON SECTIONS WITH TETHER:
NCHRP-350 TESTS 3-10, 3-11(BLON)
SCALE: 1=64

TRITON SECTIONS WITHOUT TETHER:
NCHRP-350 TEST 3-11
SCALE: 1=64

- NOTES:
- 1 USE ITEM 5 TO DOUBLE NUT U-BOLTS INSIDE BARRIER.
 - 2 ORDER TETHER SEPARATELY USING P.N. 2795494-0000.

DESIGNED D. Staus	DATE 11/5/97	ENERGY ABSORPTION SYSTEMS, INC. ENGINEERING AND RESEARCH DEPARTMENT
CHECKED KRM	DATE 11/13/97	
APPROVED LCC	DATE 11/13/97	
DATE D. June	DATE 11/13/97	
FILED 3595351-TEST.dwg	DATE	
SCALE: 1:15		3595351-TEST
		1 of 1

TRITON BARRIER®TL-3



t = 0.000 sec



t = 0.180 sec



t = 0.360 sec



t = 0.540 sec



t = 0.720 sec



t = final

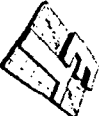
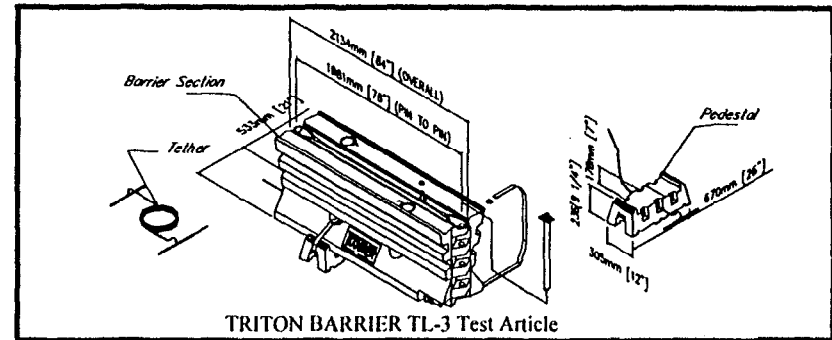
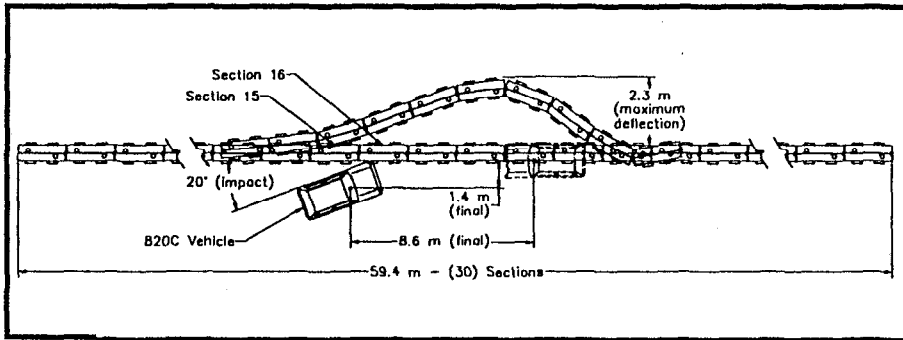

E-TECH Testing Services, Inc.

TRITON BARRIER TL-3 Crash Test Results - 5 of 25

General Information

Test Agency E-TECH Testing Services, Inc.
 Test Designation NCHRP 350 Test 3-10
 Test No. 01-7604-002
 Date 10/23/97

Test Article

Type Energy Absorption Systems, Inc.
 TRITON BARRIER TL-3

Installation Length 59.4 m - (30) Sections

Size and/or dimension and material
 of key elements 1981 mm Section Length
 178 mm Pedestal Height
 Polyethylene Plastic

Test Vehicle

Type Production Model
 Designation 820C
 Model 1988 Ford Festiva
 Hatchback

Mass (kg)
 Curb 738
 Test inertial 800
 Dummy(s) 75
 Gross Static 875

Impact Conditions

Speed (km/h) 97.04
 Angle (deg) 21.0
 Impact Severity (kJ) 37.33

Exit conditions

Speed (km/h) N/A
 Angle (deg) N/A

Occupant Risk Values

Impact Velocity (m/s)
 x-direction 11.04
 y-direction -2.94
 Ridedown Acceleration (g's)
 x-direction -12.23
 y-direction 9.55
 THIV (m/s) 11.55
 PHD (g's) 10.47
 ASI 1.05

Test Article Deflections (m)

Dynamic 2.3
 Permanent 2.3

Vehicle Damage

Exterior
 VDS FD-5
 CDC 11FDEW5
 Interior
 OCIDI LS0010000

Post-Impact Vehicular Behavior (deg - gyro @ c.g.)

Maximum Roll Angle -11.06
 Maximum Pitch Angle -4.38
 Maximum Yaw Angle -158.08

Figure 1. Summary of Results - TRITON BARRIER TL-3 Test 01-7604-002

ENCLOSURE 2 - 1 OF 4



t = 0.000 sec



t = 0.180 sec

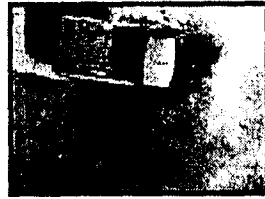

t = 0.360 sec



t = 0.540 sec



t = 0.720 sec



t = final

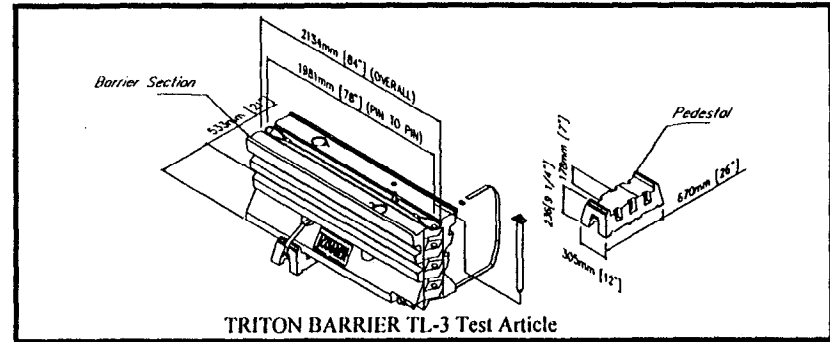
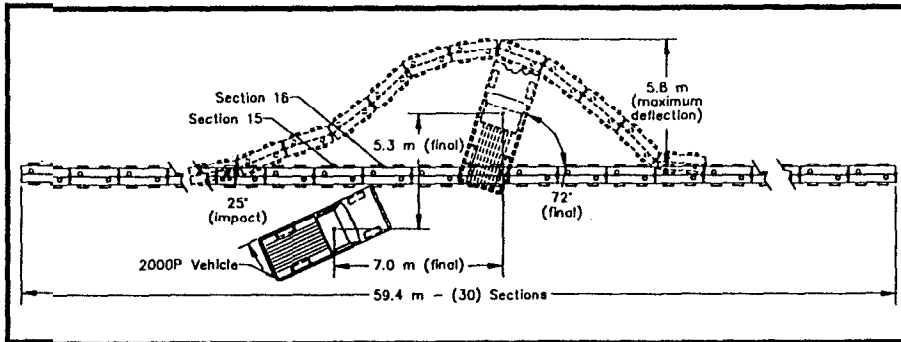

TRITON BARRIER TL-3 Crash Test Results -11 of 25

General Information

Test Agency E-TECH Testing Services, Inc.
 Test Designation NCHRP 350 Test 3-11
 Test No. 01-7604-001
 Date 10/15/97

Test Article

Type Energy Absorption Systems, Inc.
 TRITON BARRIER TL-3

Installation Length 59.4 m - (30) Sections

Size and/or dimension and material
 of key elements 1981 mm Section Length
 178 mm Pedestal Height
 Polyethylene Plastic

Test Vehicle

Type Production Model
 Designation 2000P
 Model 1990 Chevrolet C2500
 3/4T Pickup
 Mass (kg)
 Curb 1956
 Test inertial 2005
 Dummy(s) N/A
 Gross Static 2005

Impact Conditions

Speed (km/h) 97.56
 Angle (deg) 25.0
 Impact Severity (kJ) 131.51

Exit conditions

Speed (km/h) N/A
 Angle (deg) N/A

Occupant Risk Values

Impact Velocity (m/s)
 x-direction 9.06
 y-direction 1.05
 Ridedown Acceleration (g's)
 x-direction -10.09
 y-direction -4.95
 THIV (m/s) 9.10
 PHD (g's) 8.88
 ASI 0.69

Test Article Deflections (m)

Dynamic 5.8
 Permanent 5.8

Vehicle Damage

Exterior
 VDS FD-5
 CDC 11FDEW5
 Interior
 OC DI LS2000000

Post-Impact Vehicular Behavior (deg - gyro @ c.g.)

Maximum Roll Angle 12.08
 Maximum Pitch Angle -3.79
 Maximum Yaw Angle -47.20

E-TECH Testing Services, Inc.

ENCLOSURE 2 - 2 OF 4

Figure 5. Summary of Results - TRITON BARRIER TL-3 Test 01-7604-001



t = 0.000 sec



t = 0.180 sec



t = 0.360 sec

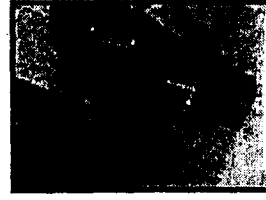

t = 0.540 sec



t = 0.720 sec



t = final

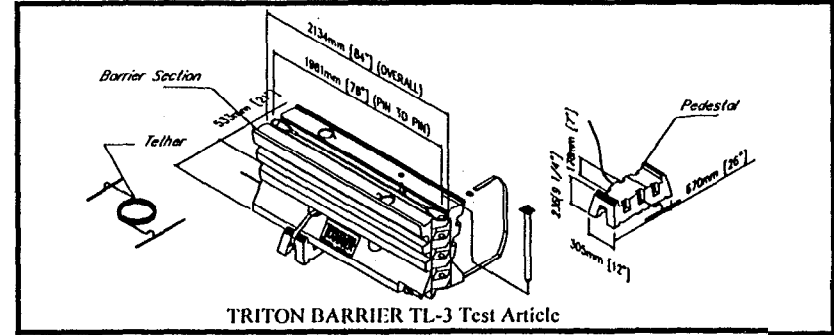
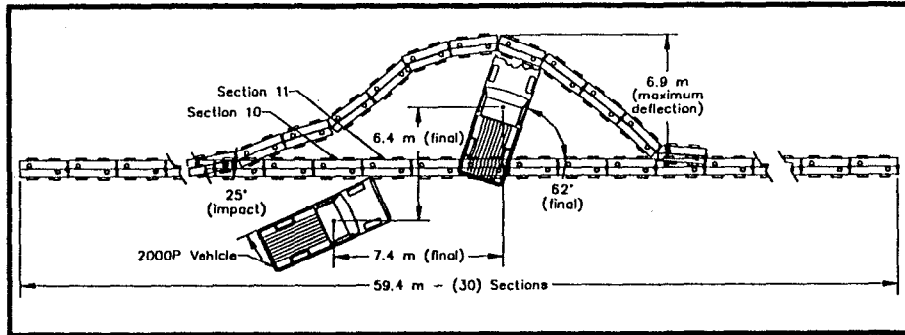

E-TECH Testing Services, Inc.

TRITON BARRIER TL-3 Crash Test Results -17 of 25

General Information

Test Agency E-TECH Testing Services, Inc.
 Test Designation NCHRP 350 Test 3-11
 Test No. 01-7604-003
 Date 10/29/97

Test Article

Type Energy Absorption Systems, Inc.
 TRITON BARRIER TL-3

Installation Length 59.4 m - (30) Sections

Size and/or dimension and material
 of key elements 1981 mm Section Length
 178 mm Pedestal Height
 Polyethylene Plastic

Test Vehicle

Type Production Model
 Designation 2000P
 Model 1990 Chevrolet C2500
 3/4T Pickup
 Mass (kg)
 Curb 2023
 Test inertial 2017
 Dummy(s) N/A
 Gross Static 2017

Impact Conditions

Speed (km/h) 96.26
 Angle (deg) 25.0
 Impact Severity (kJ) 128.81

Exit conditions

Speed (km/h) N/A
 Angle (deg) N/A
Occupant Risk Values
 Impact Velocity (m/s)
 x-direction 8.70
 y-direction 0.31
 Ridedown Acceleration (g's)
 x-direction -8.31
 y-direction 7.45
 THIV (m/s) 8.73
 PHD (g's) 7.75
 ASI 0.66
Test Article Deflections (m)
 Dynamic 6.9
 Permanent 6.9
Vehicle Damage
 Exterior
 VDS FD-5
 CDC 11FDEW5
 Interior
 OCDI AS0000000
Post-Impact Vehicular Behavior (deg - gyro @ c.g.)
 Maximum Roll Angle 13.01
 Maximum Pitch Angle 3.12
 Maximum Yaw Angle -37.12

Figure 11. Summary of Results - TRITON BARRIER TL-3 Test 01-7604-003

ENCLOSURE 2 - 3 OF 4

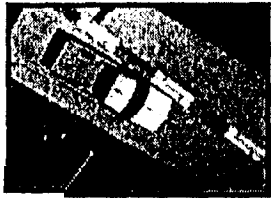

t = 0.000 sec

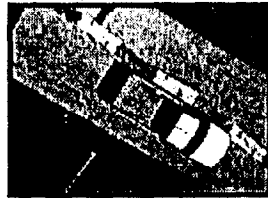

t = 0.120 sec

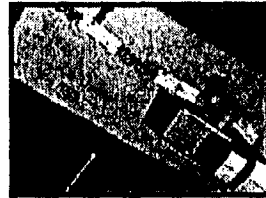

t = 0.180 sec

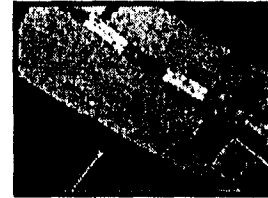

t = 0.240 sec

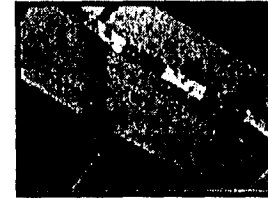

t = 0.300 sec

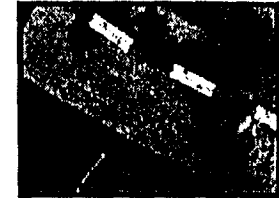

t = final

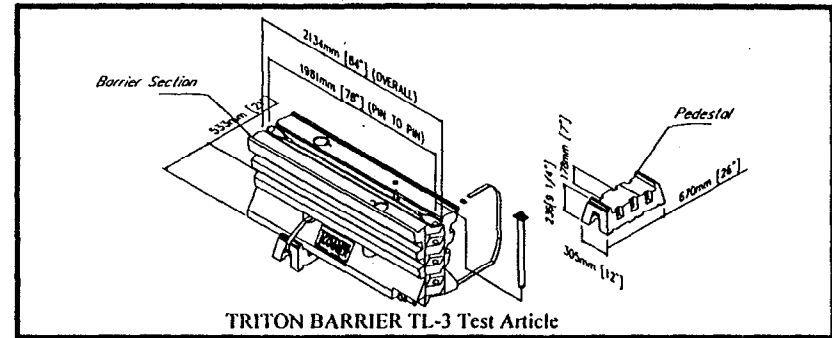
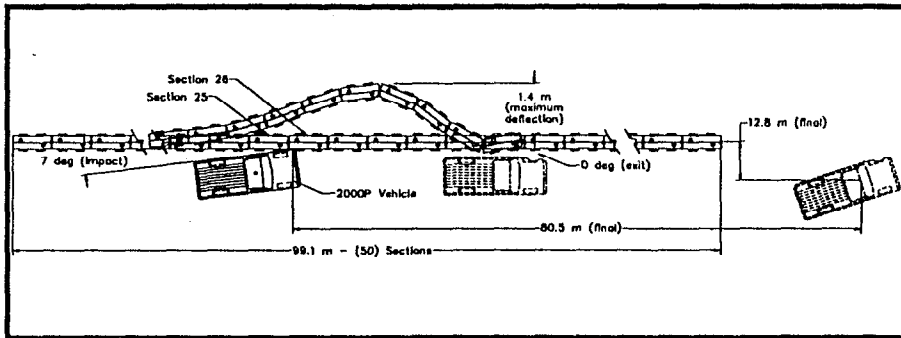

E-TECH Testing Services, Inc.

General Information

Test Agency E-TECH Testing Services, Inc.
 Test Designation NCHRP 350 Test 3-11 Modified
 Test No. 0 1-7604-005
 Date 3/18/98

Test Article

Type Energy Absorption Systems, Inc.
 TRITON BARRIER TL-3

Installation Length 99.1 m - (50) Sections

Size and/or dimension and material
 of key elements 1981 mm Section Length
 178 mm Pedestal Height
 Polyethylene Plastic

Test Vehicle

Type Production Model
 Designation 2000P
 Model 1990 Chevrolet C2500
 3/4T Pickup

Mass (kg)
 Curb 1894
 Test inertial 2004
 Dummy(s) N/A
 Gross Static 2004

Impact Conditions

Speed (km/h) 95.74
 Angle (deg) 7.0
 Impact Severity (kJ) 10.53

Exit conditions

Speed (km/h) 83.52
 Angle (deg) 0

Occupant Risk Values

Impact Velocity (m/s)
 x-direction 4.15
 y-direction 2.46
 Ridedown Acceleration (g's)
 x-direction -4.41
 y-direction 3.99
 THIV (m/s) 4.96
 PHD (g's) 3.01
 ASI 0.35

Test Article Deflections (m)

Dynamic 1.4
 Permanent 1.4

Vehicle Damage

Exterior
 VDS LD-5
 CDC 10LDEW1
 Interior
 OCDI AS0000000

Post-Impact Vehicular Behavior (deg - gyro @ c.g.)

Maximum Roll Angle 16.95
 Maximum Pitch Angle 7.54
 Maximum Yaw Angle 15.58

TRITON BARRIER TL-3 Crash Test Results - 1 of 1

Summary of Results - TRITON BARRIER® TL-3 at 7 Degree Impact Angle Test 01-7604-005



U.S. Department
of Transportation
**Federal Highway
Administration**

400 Seventh St., S.W.
Washington, D.C. 20590

May 8, 1998

Refer to: HNG-14

J. M. Essex, P.E.
Senior Vice President, Sales
Energy Absorption Systems, Inc.
One East Wacker Drive
Chicago, Illinois 60601

Dear Mr. Essex:

In your April 1 letter to Mr. Henry Rentz, you requested acceptance of a modified Triton barrier at the National Cooperative Highway Research Program (NCHRP) Report 350 test level 3 (TL-3) and acceptance of the Triton barrier as its own nonredirecting TL-3 end treatment when the initial module is installed upside down and left empty of water. This letter contains the Federal Highway Administration's response to the end treatment request. The barrier itself was accepted as a TL-3 system in my May 7 letter to you.

To support your request, you sent copies of your report entitled "TRITON BARRIER TL-3 End Treatment: Qualification to the NCHRP Report 350 Test Level 3 - Engineering Summary," dated December 19, 1997, which included the full report prepared by E-TECH Testing Services, Inc., entitled "NCHRP Report 350 Crash Test Results for the TRITON BARRIER TL-3 End Treatment," also dated December 1997, and a video tape showing the full scale tests that you conducted on the Triton TL-3 end treatment. The TRITON BARRIER TL-3 End Treatment consists of ten sections. The first, or lead section, is an inverted, empty TL-2 TRITON module supported and raised 130 mm by a modified plastic pedestal. Sections two through ten are standard TL-2 TRITON modules filled with water and set on 178-mm high plastic pedestals. Thus, sections two through ten are identical to the TRITON BARRIER TL-3 modules to which the end terminal must be attached. The terminal system is shown on Enclosure 1.

Since the TRITON end treatment is a nonredirective terminal, NCHRP Report 350 guidelines recommend tests 3-40 through 3-44 be conducted. We note that all five tests were run and we agree that appropriate evaluation criteria were met in each test. Enclosure 2 shows the test matrix that you ran and summarizes the evaluation criteria for each test. Enclosure 3 provides

additional information on the individual tests, including the final stopping position of the test vehicles. We also noted that a concrete backup was used in each of your terminal tests. While this did not affect the test results, users must be made aware that the TRITON End Terminal is not acceptable for shielding longitudinal barriers other than the TRITON BARRIER TL-3 itself.

Based on our review of the information you provided, we concur that the TRITON BARRIER TL-3 end treatment, as tested, meets the acceptance criteria for an NCHRP Report 350 TL-3 nonredirective terminal when used to shield the end of a length of Triton TL-3 barrier. It may be used on the National Highway System (NHS) when such use is specified by, or acceptable to, a transportation agency. Because it is a proprietary device, its use on Federal-aid projects, except exempt, non-NHS projects, remains subject to the conditions listed in Title 23, Code of Federal Regulations, Section 635.411 when its use is specified by the contracting authority.

Sincerely yours,

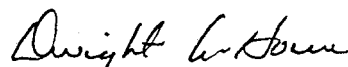

Dwight A. Home
Chief, Federal-Aid and Design Division

3 Enclosures

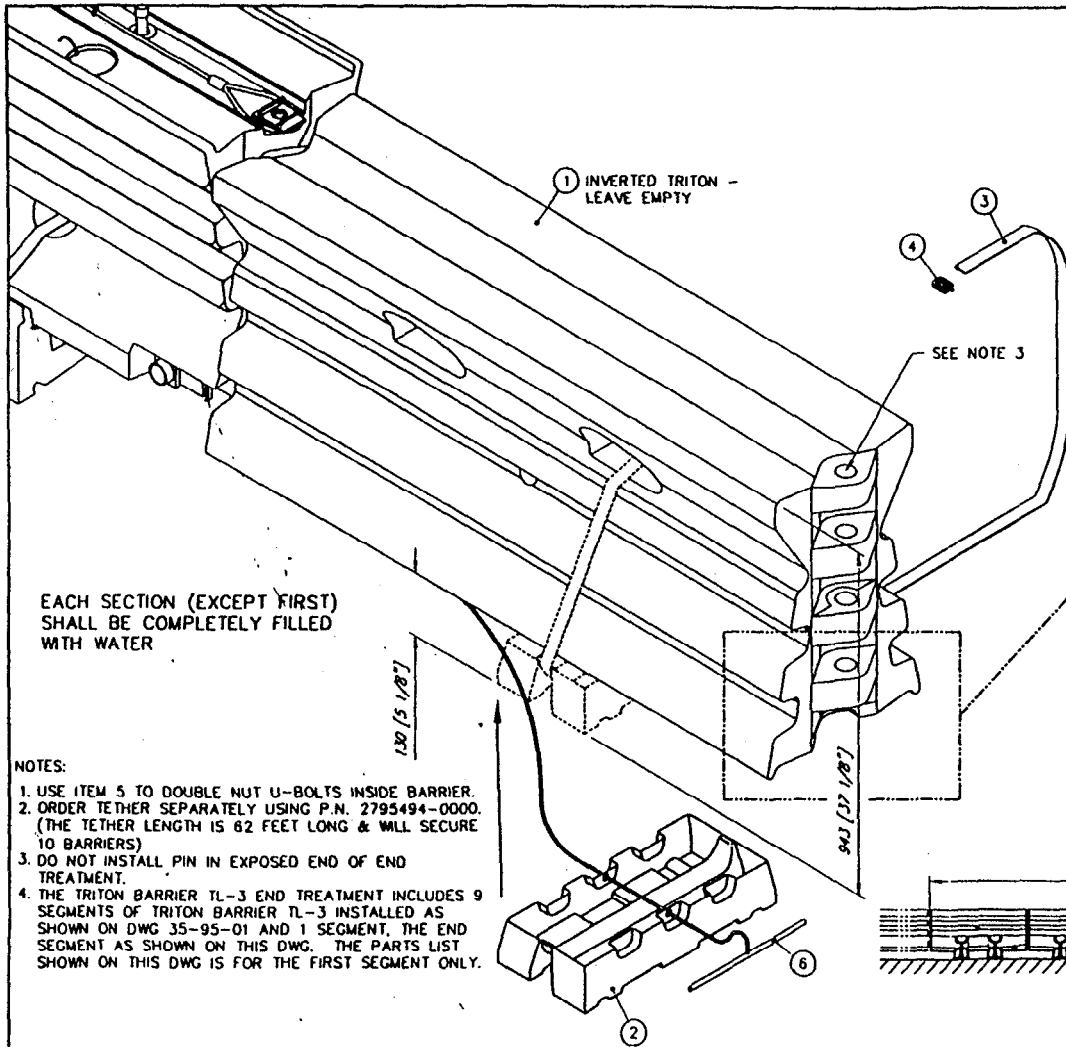

EACH SECTION (EXCEPT FIRST) SHALL BE COMPLETELY FILLED WITH WATER

NOTES:

1. USE ITEM 5 TO DOUBLE NUT U-BOLTS INSIDE BARRIER.
2. ORDER TETHER SEPARATELY USING P.N. 2795494-0000. (THE TETHER LENGTH IS 62 FEET LONG & WILL SECURE 10 BARRIERS)
3. DO NOT INSTALL PIN IN EXPOSED END OF END TREATMENT.
4. THE TRITON BARRIER TL-3 END TREATMENT INCLUDES 9 SEGMENTS OF TRITON BARRIER TL-3 INSTALLED AS SHOWN ON DWG 35-95-01 AND 1 SEGMENT, THE END SEGMENT AS SHOWN ON THIS DWG. THE PARTS LIST SHOWN ON THIS DWG IS FOR THE FIRST SEGMENT ONLY.

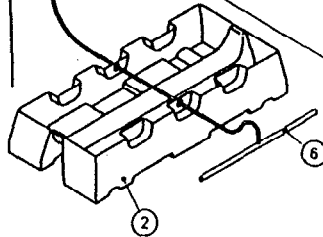

PARTS LIST				
ITEM	STOCK NO.	DESCRIPTION	QTY	
*ORANGE - 0100	1	2795041-0*00	BARRIER SECTION, TRI,*	1.00
*WHITE - 0000	2	2795496-0000	PEDESTAL, SHORT, TRITON, TL-3	1.00
	3	2795492-0000	STRAP, TRITON, TL-3	1.00
3595361-0000	4	2795493-0000	BUCKLE, TRITON, TL-3	1.00
	5	2704011-0000	NUT, HX, 1/2, G (SEE NOTE 1 & CUTAWAY)	4.00
	6	2795494-0000	TETHER, TRITON, TL-3 (SEE NOTE 2)	1.00

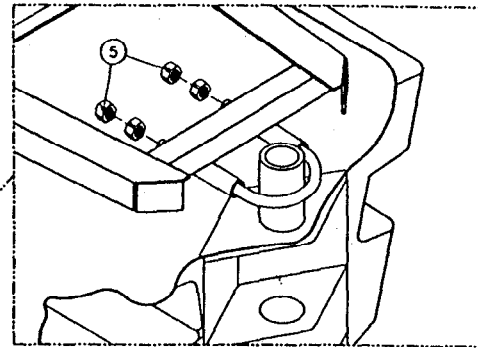

CUTAWAY VIEW
(SHOWN RIGHT SIDE UP FOR CLARITY)

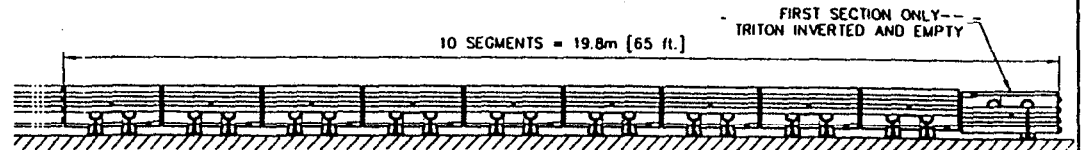

SIDE ELEVATION
(ENTIRE END TREATMENT)

Revisions	Date	Rev.	By	Ckd.	App.
CHGD TO REFLECT ONLY #2-5 INCL IN ASSY.	1/12/98	A	DLS	[Signature]	[Signature]

REFERENCES	
TRITON BARRIER ASSEMBLY	35-95-01

DESIGN: D. Staus	DATE: 12/16/97
DRAWN:	DATE:
CHECKED: KRM	DATE: 12/18/97
APPROVED: LCC	DATE: 12/18/97
CAD FILE: 3595361-0000.dwg	
NEXT ASSEMBLY:	

ENERGY ABSORPTION SYSTEMS, INC.
ENGINEERING AND RESEARCH DEPARTMENT

**TRITON BARRIER® TL-3
END TREATMENT**

SCALE: 1:15 3595361-0000 1 of 1 A

TEST MATRIX FOR CERTIFICATION OF THE TRITON BARRIER® TL-3 END TREATMENT TO NCHRP 350 TEST LEVEL 3 STANDARDS

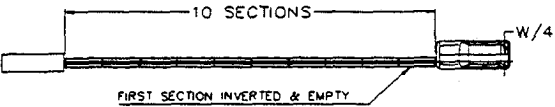
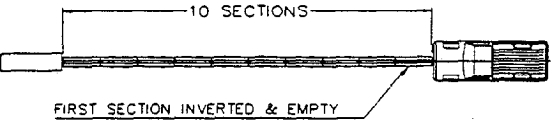
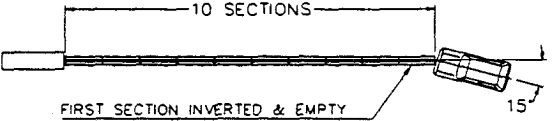
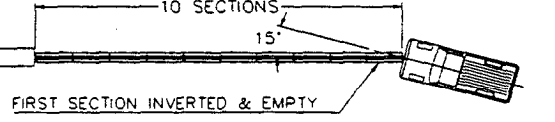
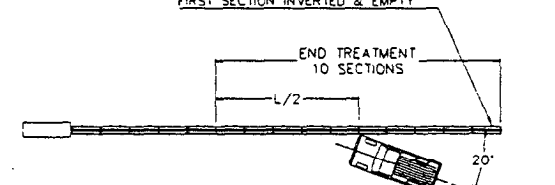
NCHRP Evaluation Criteria	E-tech Test ID. #	Test Conditions	Impact speed (km/hr)	Impact Angle (deg.)	Occupant Impact Velocity		Ridedown Accelerations		Overall Assessment	Notes
					Long. (m/sec)	Lateral (m/sec)	Long. (G)	Lateral (G)		
350-3-40	01-7605-002		101.69	0	9.67	1.33	-14.62	-9.11	PASS	
350-3-41	01-7605-001		98.90	0	9.20	0.30	-9.27	3.40	PASS	
350-3-42	01-7605-003		101.69	0	7.96	2.66	-7.50	-13.03	PASS	
350-3-43	01-7605-004		98.36	0	6.48	-2.49	-3.42	-4.11	PASS	
350-3-44	01-7605-005		99.72	20	8.52	1.32	-9.39	-7.34	PASS	Article performed by controlled penetration.



t = 0.000 sec



t = 0.240sec

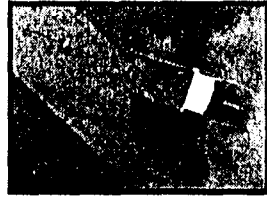

t = 0.480sec

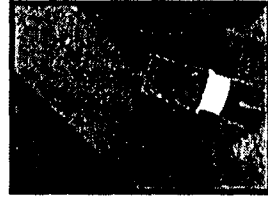

t = 0.720 sec

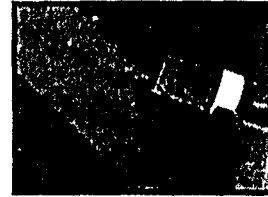

t = 0.960 set

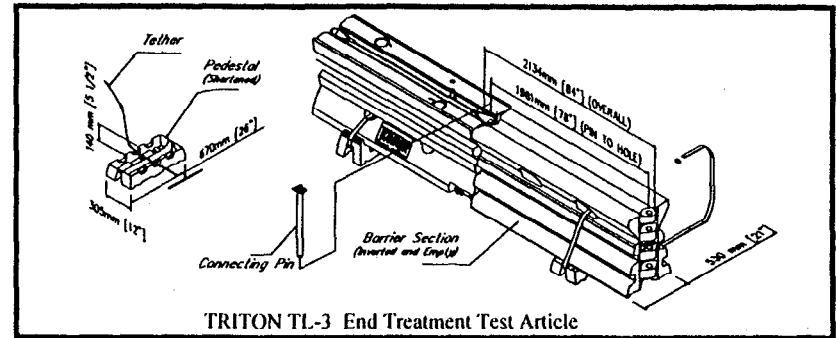
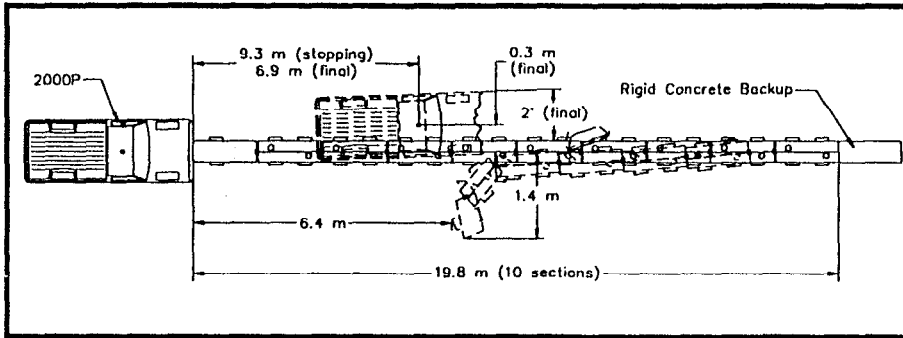
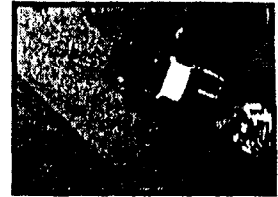

TRITON TL-3 End Treatment Test Article

General Information

Test Agency E-TECH Testing Services, Inc.
 Test Designation NCHRP 350 Test 3-41
 Test No. 01-7605-001
 Date 11/5/97

Test Article

Type Energy Absorption Systems, Inc.
 TRITON BARRIER TL-3
 End Treatment
 Installation Length 19.8 m - (10) Sections
 Size and/or dimension and material
 of key elements 1981 mm Section Length
 178 mm Pedestal Height
 Polyethylene Plastic

Test Vehicle

Type Production Model
 Designation 2000P
 Model 1989 GMC C2500
 Pickup
 Mass (kg)
 Curb 2160
 Test inertial 1993
 Dummy(s) N/A
 Gross Static 1993

Impact Conditions

Speed (km/h) 98.90
 Angle (deg) 0.0
 Impact Severity (kJ) 752.11

Exit conditions

Speed (km/h) N/A
 Angle (deg) N/A

Occupant Risk Values

Impact Velocity (m/s)
 x-direction 9.20
 y-direction 0.30
 Ridedown Acceleration (g's)
 x-direction -9.27
 y-direction 3.40
 THIV (m/s) 9.22
 PHD (g's) 8.02
 ASI 0.76

Test Article Deflections (m)

Dynamic 6.4
 Permanent 6.4

Vehicle Damage

Exterior
 VDS FD-3
 CDC 12FDEW3

Interior
 OCDI AS0000000

Post-Impact Vehicular Behavior (deg - gyro @ c.g.)

Maximum Roll Angle -29.79
 Maximum Pitch Angle 11.21
 Maximum Yaw Angle -5.33

Figure 6. Summary of Results - TRITON BARRIER TL-3 End Treatment Test 01-7605-001

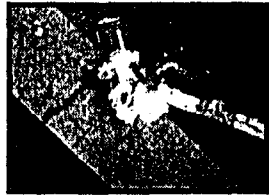
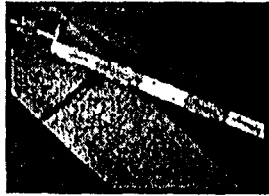

t = 0.000 sec

t = 0.300 sec

t = 0.600 sec

t = 0.900 sec

t = 1.200 sec

t = final

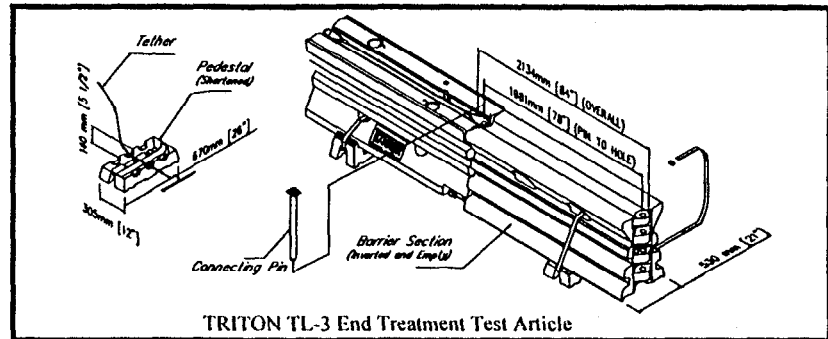
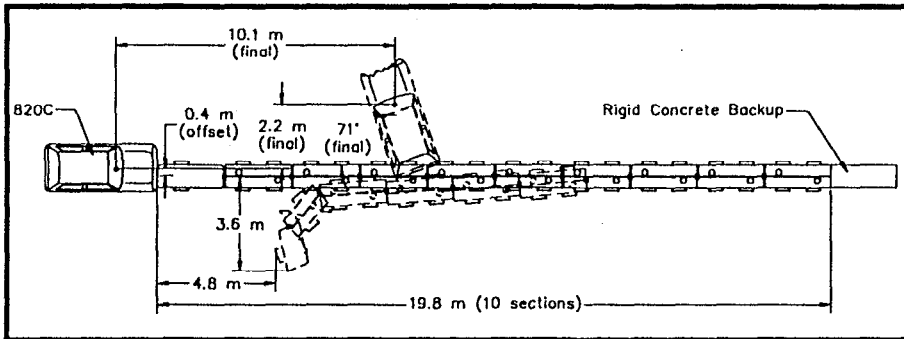

General Information

Test Agency E-TECH Testing Services, Inc.
 Test Designation NCHRP 350 Test 3-40
 Test No. 01-7605-002
 Date 11/6/97

Test Article

Type Energy Absorption Systems, Inc.
 TRITON BARRIER TL-3
 End Treatment

Installation Length 19.8 m - (10) Sections

Size and/or dimension and material
 of key elements 1981 mm Section Length
 178 mm Pedestal Height
 Polyethylene Plastic

Test Vehicle

Type Production Model
 Designation 820C
 Model 1988 Ford Festiva
 Hatchback

Mass (kg)
 Curb 769
 Test inertial 822
 Dummy(s) 75
 Gross Static 897

Impact Conditions

Speed (km/h) 101.69
 Angle (deg) 0.0
 Impact Severity (kJ) 328.16

Exit conditions

Speed (km/h) N/A
 Angle (deg) N/A

Occupant Risk Values

Impact Velocity (m/s)
 x-direction 9.67
 y-direction 1.33
 Ridedown Acceleration (g's)
 x-direction -14.62
 y-direction -9.11
 THIV (m/s) 10.27
 PHD (g's) 13.28
 ASI 1.09

Test Article Deflections (m)

Dynamic 4.8
 Permanent 4.8

Vehicle Damage

Exterior
 VDS FD-5
 CDC 12FDEW5
 Interior
 OCDI AS0000000

Post-Impact Vehicular Behavior (deg - gyro @ c.g.)

Maximum Roll Angle 11.21
 Maximum Pitch Angle -13.82
 Maximum Yaw Angle 234.19



Figure 1. Summary of Results - TRITON BARRIER TL-3 End Treatment Test 01-7605-002

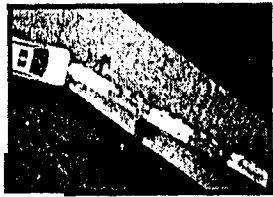

t = 0.000 sec

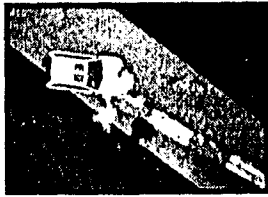

t = 0.120 sec

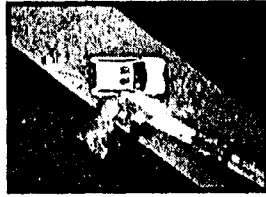

t = 0.240 sec

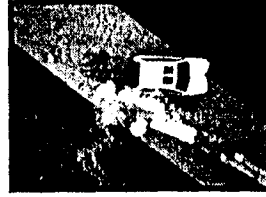

t = 0.360 sec

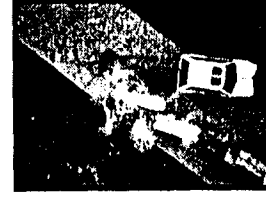

t = 0.480 sec

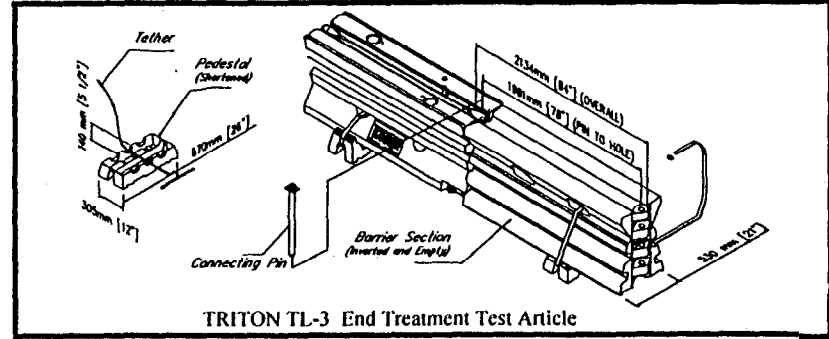
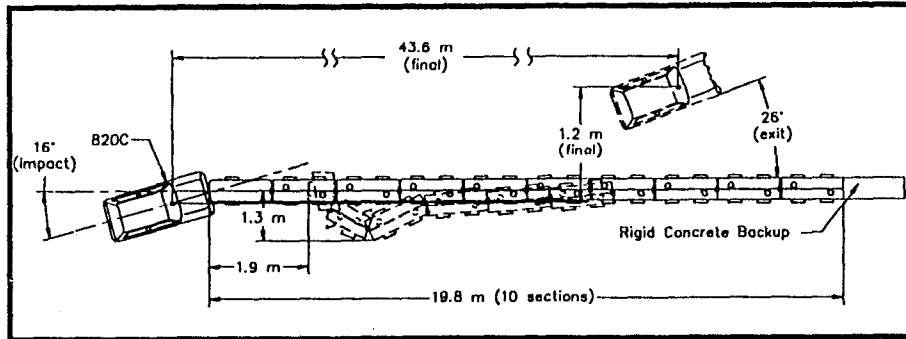

TRITON TL-3 End Treatment Test Article

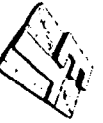

E-TECH Testing Services, Inc.

ENCLOSURE 3 - 3 OF 5

TRITON TL-3 End Treatment Crash Test Results - 17 of 37

General Information

Test Agency E-TECH Testing Services, Inc.
 Test Designation NCHRP 350 Test 3-42
 Test No. 01-7605-003
 Date 11/10/97

Test Article

Type Energy Absorption Systems, Inc.
 TRITON BARRIER TL3
 End Treatment
 Installation Length 19.8 m -(10) Sections
 Size and/or dimension and material
 of key elements 1981 mm Section Length
 178 mm Pedestal Height
 Polyethylene Plastic

Test Vehicle

Type Production Model
 Designation 820C
 Model 1988 Ford Festiva
 Hatchback
 Mass (kg)
 Curb 824
 Test inertial 823
 Dummy(s) 75
 Cross Static 898

Impact Conditions

Speed (km/h) 101.69
 Angle (deg) 16.0
 Impact Severity (kJ) 328.56

Exit conditions

Speed (km/h) 63.0
 Angle (deg) 26.0

Occupant Risk Values

Impact Velocity (m/s)
 x-direction 7.96
 y-direction 2.66
 Ridedown Acceleration (g's)
 x-direction -7.50
 y-direction -13.03
 THIV (m/s) 8.92
 PHD (g's) 10.59
 ASI 1.06

Test Article Deflections (m)

Dynamic 1.9
 Permanent 1.9

Vehicle Damage

Exterior
 VDS FD-3
 CDC 12FDEW3
 Interior
 OCDI AS0000000

Post-Impact Vehicular Behavior (deg - gyro @ c.g.)

Maximum Roll Angle -12.97
 Maximum Pitch Angle -6.09
 Maximum Yaw Angle 59.12

Figure 11. Summary of Results - TRITON BARRIER TL-3 End Treatment Test 01-7605-003

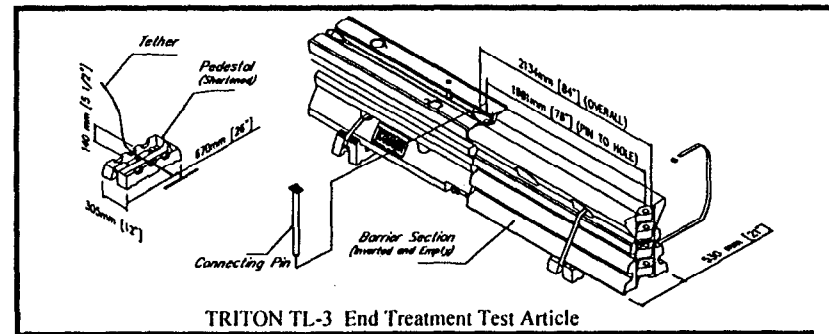
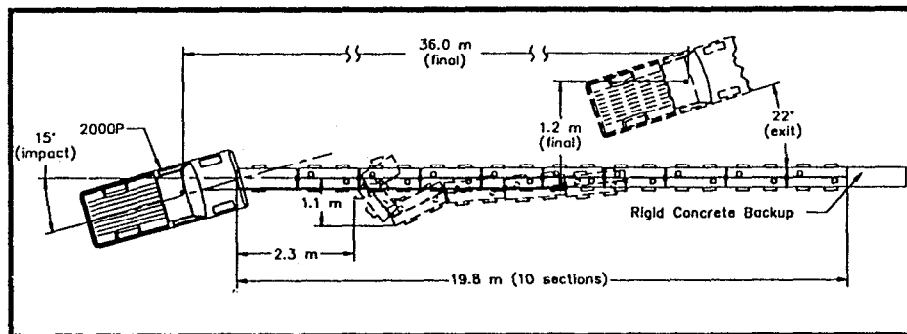
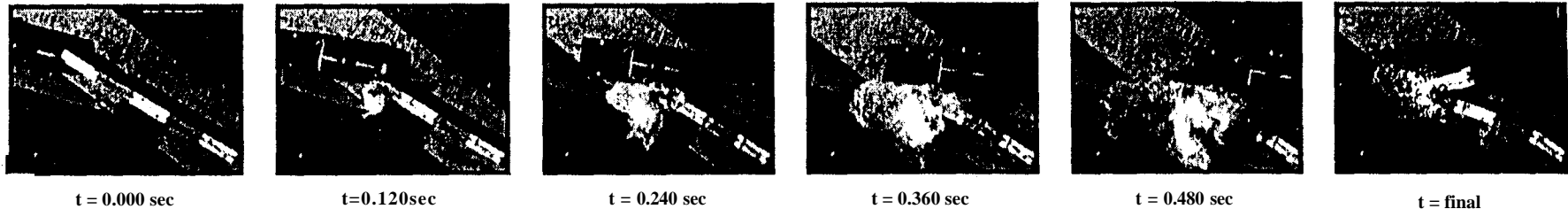

E-TECH Testing Services, Inc.

General Information

Test Agency E-TECH Testing Services, Inc.
 Test Designation NCHRP 350 Test 3-43
 Test No. 01-7605-004
 Date 11/12/97

Test Article

Type Energy Absorption Systems, Inc.
 TRITON BARRIER TL-3
 End Treatment
 Installation Length 19.8 m - (10) Sections
 Size and/or dimension and material
 of key elements 1981 mm Section Length
 178 mm Pedestal Height
 Polyethylene Plastic

Test Vehicle

Type Production Model
 Designation 2000P
 Model 1988 GMC C2500
 Pickup
 Mass (kg)
 Curb 1947
 Test inertial 1998
 Dummy(s) N/A
 Gross Static 1998

Impact Conditions

Speed (km/h) 98.36
 Angle (deg) 15.0
 Impact Severity (kJ) 745.79

Exit conditions

Speed (km/h) 73.4
 Angle (deg) 22.0

Occupant Risk Values

Impact Velocity (m/s)
 x-direction 6.48
 y-direction -2.49
 Ridedown Acceleration (g's)
 x-direction -3.42
 y-direction -4.11
 THIV (m/s) 6.83
 PHD (g's) 2.72
 ASI 0.53

Test Article Deflections (m)

Dynamic 2.3
 Permanent 2.3

Vehicle Damage

Exterior
 VDS FD-3
 CDC 12FDEW3
 Interior
 OCDI AS0000000

Post-Impact Vehicular Behavior (deg -gyro @ c.g.)

Maximum Roll Angle -5.14
 Maximum Pitch Angle 2.00
 Maximum Yaw Angle -8.03

TRITON TL-3 End Treatment Crash Test Results - 23 of 37

Figure 16. Summary of Results - TRITON BARRIER TL-3 End Treatment Test 01-7605-004



t = 0.000 sec

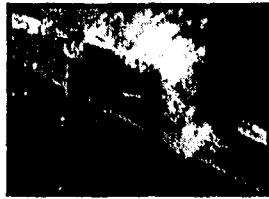

t = 0.240 sec



t = 0.480 sec



t = 0.720 sec



t = 0.960 sec

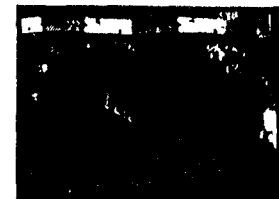

t = final

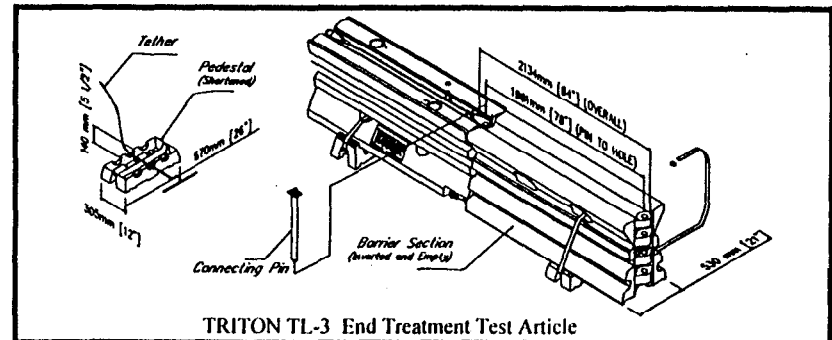
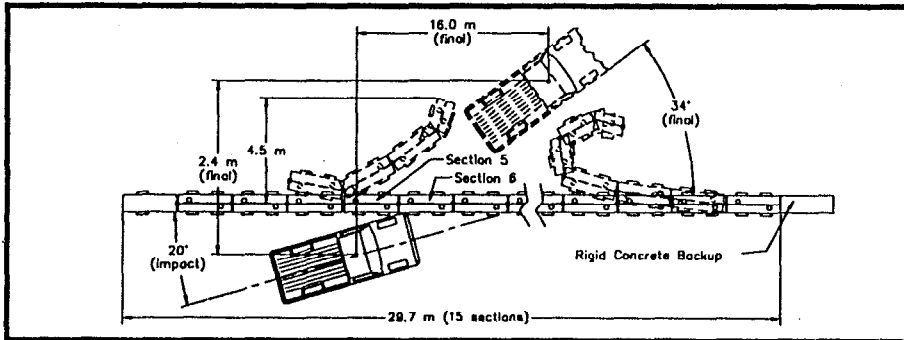

E-TECH Testing Services, Inc.

General Information

Test Agency E-TECH Testing Services, Inc.
 Test Designation NCHRP 350 Test 3-44
 Test No 01-7605-005
 Date 11/17/97

Test Article

Type Energy Absorption Systems, Inc.
 TRITON BARRIER TL-3
 End Treatment

Installation Length 29.7 m - (15) Sections

Size and/or dimension and material
 of key elements 1981 mm Section Length
 178 mm Pedestal Height
 Polyethylene Plastic

Test Vehicle

Type Production Model
 Designation 2000P
 Model 1990 Chevrolet C2500
 Pickup

Mass (kg)
 Curb 1947
 Test inertial 1997
 Dummy(s) N/A
 Gross Static 1997

Impact Conditions

Speed (km/h) 99.72
 Angle (deg) 20.0
 Impact Severity (kJ) 766.14

Exit conditions

Speed (km/h) 1.6
 Angle (deg) 30.0

Occupant Risk Values

Impact Velocity (m/s)
 x-direction 8.52
 y-direction 1.32
 Ridedown Acceleration (g's)
 x-direction -9.39
 y-direction -7.34
 THJV (m/s) 8.63
 PHD (g's) 8.66
 ASI 0.73

Test Article Deflections (m)

Dynamic 4.5
 Permanent 4.5

Vehicle Damage

Exterior
 VDS FD 3
 CDC 11FDEW3
 Interior
 OCDI AS0000000

Post-Impact Vehicular Behavior (deg - gyro @ c.g.)

Maximum Roll Angle 20.16
 Maximum Pitch Angle -6.07
 Maximum Yaw Angle -14.03

TRITON TL-3 End Treatment Crash Test Results - 29 of 37

Figure 21. Summary of Results - TRITON BARRIER TL-3 End Treatment Test 01-7605-005

ENCLOSURE 3 - 5 OF 5