

# Quest™ CEN

## Model Number Description with connection panel options

### TDXXCEN610-ZZZ

Where XX represents the performance level

|     |                   |
|-----|-------------------|
| 80  | 80 km/h (50 mph)  |
| 100 | 100 km/h (62 mph) |
| 110 | 110 km/h (69 mph) |

Where -ZZZ represents the connection panel(s) provided (if any)

|       |   |
|-------|---|
| -WL   | to W-Beam, left side only                           |
| -WR   | to W-Beam, right side only                          |
| -WLR  | to W-Beam, both left and right sides                |
| -TL   | to Thrie Beam, left side only                       |
| -TR   | to Thrie Beam, right side only                      |
| -TLR  | to Thrie Beam, both left and right sides            |
| -SL   | to Safety-shaped barrier, left side only            |
| -SR   | to Safety-shaped barrier, right side only           |
| -SLR  | to Safety-shaped barrier, both left and right sides |
| -ESL  | to vertical concrete, left side only                |
| -ESR  | to vertical concrete, right side only               |
| -ESLR | to vertical concrete, both left and right sides     |

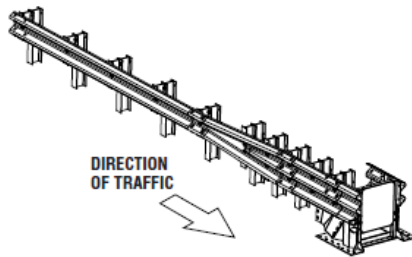

W – connection to W-Beam

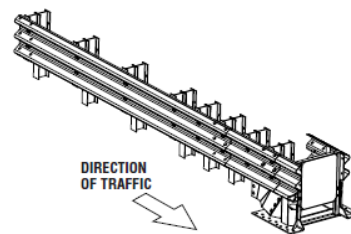

T – connection to Thrie Beam

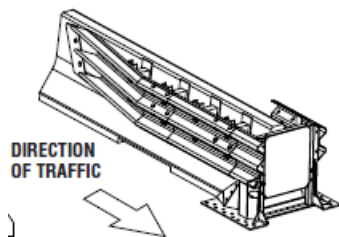

S – connection to Safety-shaped barrier

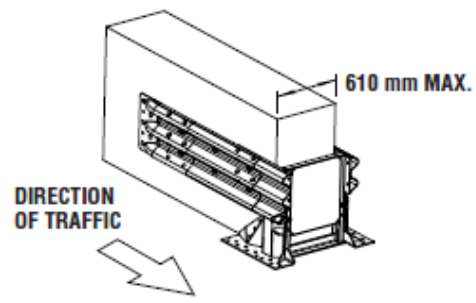

ES – connection to vertical concrete